

REVISIONS		
ISS	ZONE	DESCRIPTION\PER REQUEST\DATE
B	A-1	NO.3 WAS CHANGED\RD-DM90070301Y\07-03-01'

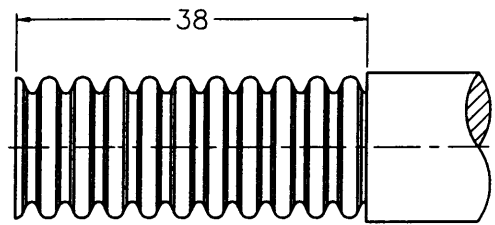

RECOMMENDED
CABLE STRIPPING DIM'S
(建議剝線尺寸)

SALES

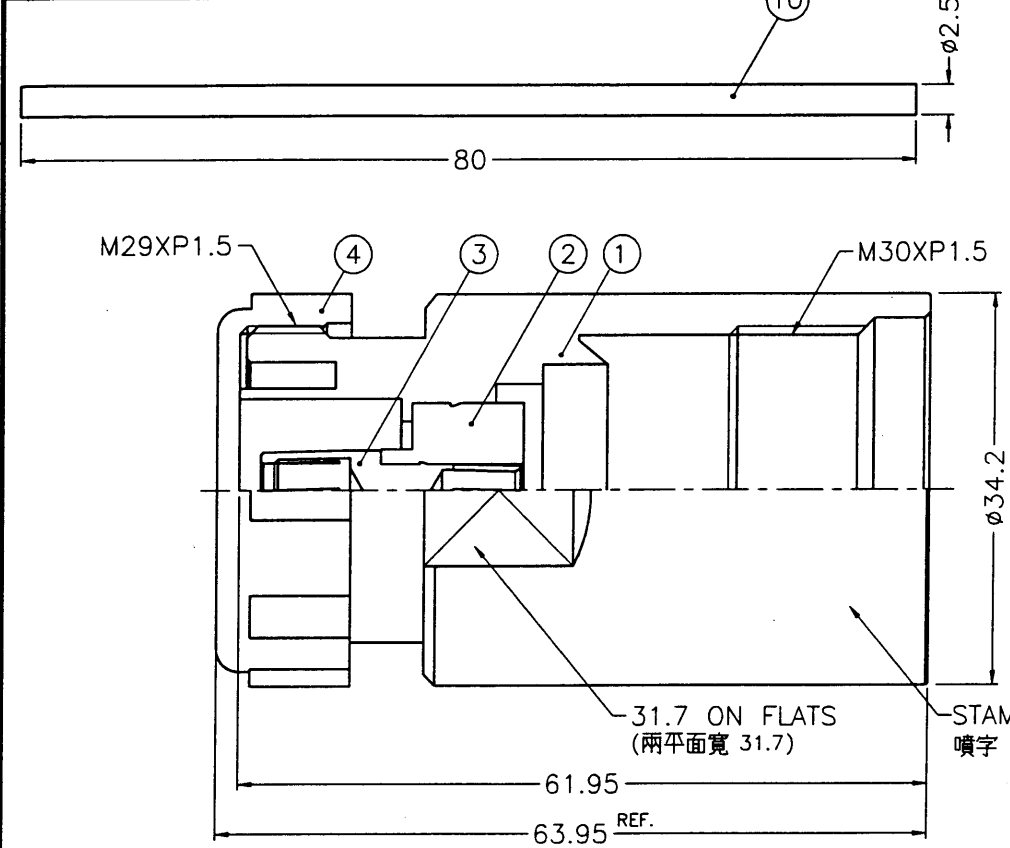
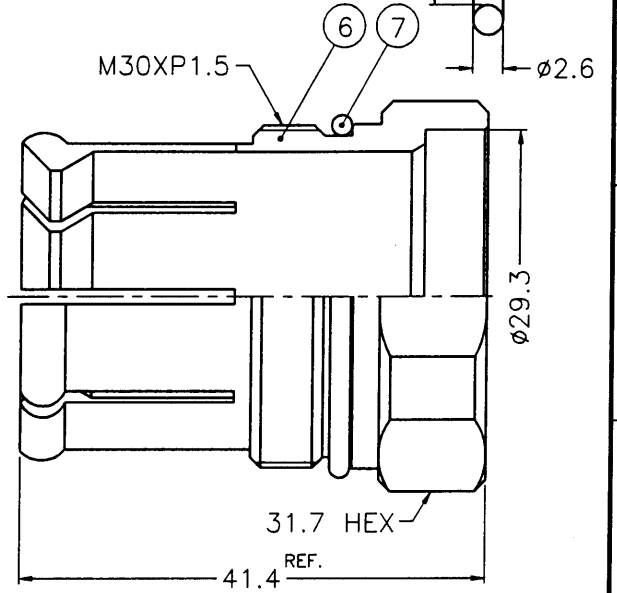
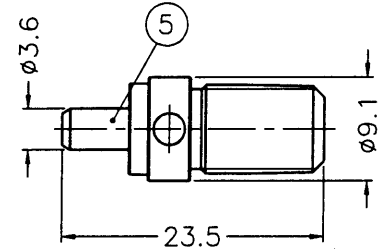

- NOTES: FINISH (PLATING THICKNESS IN MICRO-INCHES)
1. BRASS PER QQ-B-626
 2. COPPER-TIN-ZINC ALLOY
 3. BERYLLIUM COPPER PER QQ-C-530
 4. SILVER PL. 200 MIN. THICK OVER COPPER STRIKE
 5. TEFLON MIL-P-19468
 6. BLUE, PER PANTONE 3005C
 7. SILICONE GREASE PER POLYTEX 55-M OR EQUIVALENT
 8. NICKEL PL. 100 MIN. THICK OVER COPPER STRIKE

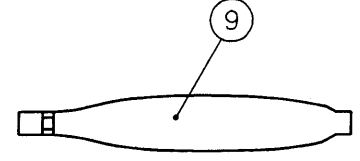

10	TOOL BAR	S45C	NOTE 8	1	N87070303-11
9	LUBRICATOR	NOTE 7	NOTE 7	1	N87070302-11
8	GASKET	SILICONE	RED	1	GS-24/188XD26
7	GASKET	SILICONE	RED	1	GS-304/27XD17
6	NUT	NOTE 1	NOTE 2	1	N87070303-7
5	CONTACT PIN	NOTE 1	NOTE 4	1	7166141A1-5-7/8A
4	COVER	PE	NOTE 6	1	7166141A1-9
3	CONTACT PIN	NOTE 3	NOTE 4	1	7166141A1-3-B
2	INSULATOR	NOTE 5	NATURAL	1	7161141A1-2T-50
1	BODY	NOTE 1	NOTE 2	1	7166141A1-1-7/8A
NO.	DESCRIPTION	MATERIAL	FINISH	Q'TY	DRAWING NO.

DIMENSIONS ARE IN MILLIMETERS
UNLESS OTHERWISE SPECIFIED TOLERANCES

0.5-6	= ±0.2
6-30	= ±0.4
30-120	= ±0.6
120-315	= ±1
315-1000	= ±1.6
1000-2000	= ±2.4

PART NO.	
APPROVED	DATE 07-10-01'
CHECKED	DATE 07-10-01'
DRAWN	DATE 07-10-01'

Amphenol - Kai Jack	
TAINAN TAIWAN	
TITLE	7/16 CLAMP JACK (FOR ANDREW 7/8" LDF5-50A HELIAX CABLE)
DRAWING NO.	KJ-7166141A1-N/NTS-7/8A-50
FILE NO.	F:\DWG\716\6141A1\78A-50\NNTS